



KITCHEN APPLIANCES AND STORAGE.

2024

HOB



78cm 2-Burner Gas Hob

Art. No. 533.02.889	
Frame	Black Tempered Glass
Burner Power	4.2kW
Knob Type	Radio
Battery System	Ignition
Wok Stand	Cast Iron
High Thermal Efficiency	50%
Flexible Bottom Plate Size	630-690 x 330 - 380 mm
Glass Size	780 x 420mm
Burner Size	110 x 110 mm
Double Jet System	
With Safety Device	
Price RM 1,499.00	

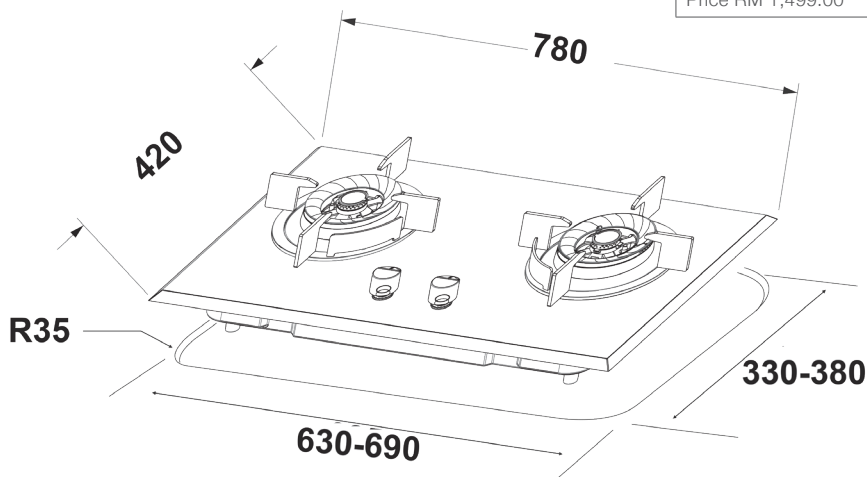

HOB

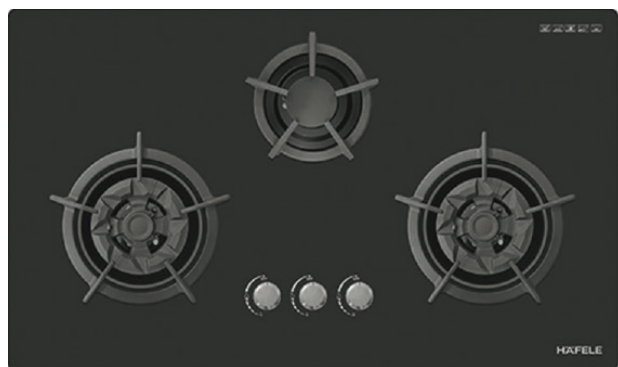

90cm 3-Burner Gas Hob

Art. No. 533.02.876	
Frame	Black Tempered Glass
Burner Power	4.5kW
Knob Type	Stylish
Battery System	ignition
Wok Stand	Cast Iron
High Thermal Efficiency	57%
Flexible Bottom Plate Size	670-850x 370-490 mm
Glass Size	900 x 525 mm
Burner Size	130 x 130mm
Double Jet System	
With Safety Device	
Price RM 2,399.00	

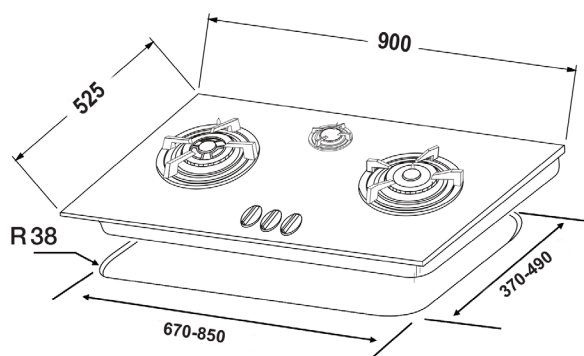

80cm 2-Burner Gas Hob

Art. No. 533.02.865	
Frame	Black Tempered Glass
Burner Power	4.5kW
Knob Type	Stylish
Battery System	ignition
Wok Stand	Cast Iron
High Thermal Efficiency	57 %
Flexible Bottom Plate Size	650-760x 350-450 mm
Glass Size	800 x 500mm
Burner Size	130 x 130 mm
Double Jet System	
With Safety Device	
Price RM 2,199.00	

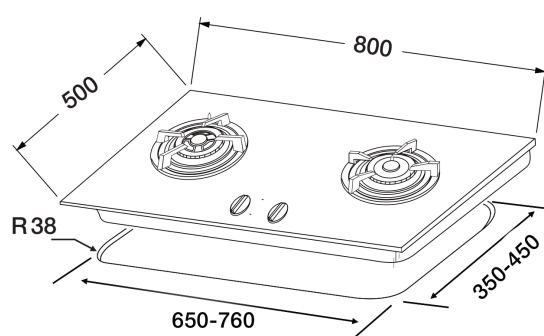
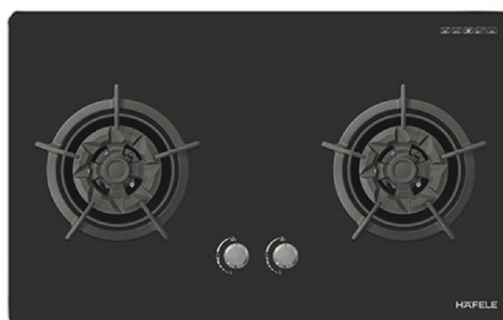

HOOD



T SLIM HOOD DC MOTOR

Art. No. 532.82.013	
Suction	1700m³/h
Panel	Black
Motor	Silent DC Motor
Panel Operation	Touch Panel with Indication
Panel Operation	9 Speed / Wave Motion
Installation	Ventilation Only
Maintenance	Auto Clean Device
Light	LED
Product Dimension	900W x 221D x 848-1248H mm
Price	RM 3,099.00

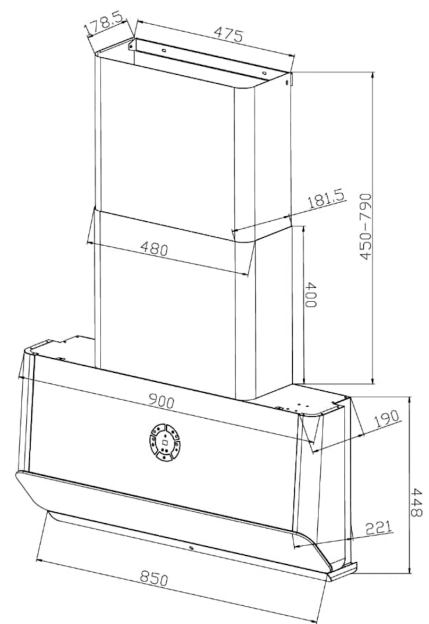

HOOD

WARRANTY
8
YEARS
MOTOR

WARRANTY
2
YEARS
GENERAL

WARRANTY
3
YEARS
TOUGH PANEL



90CM 9-Speed Auto Heating DC Motor T-Shape Hood

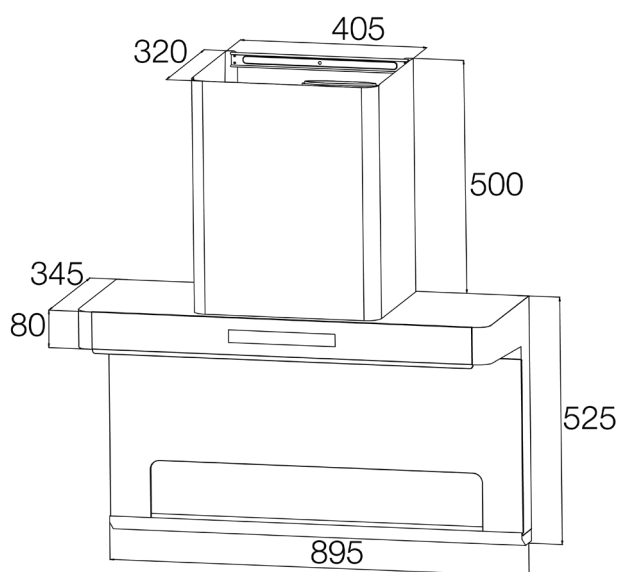

Art. No. 495.38.347

Suction	1700m ³ /h
Panel Material	Black Glass
Body Material	Enamel Black Coating
Motor	Silent DC- motor
Panel Operation	Touch Panel with Indication
Maintenance	Auto Clean Device
Oil Contena	Enamel Black Coating
	Charcoal Filter
Product Dimension	895W x 345D x 1025-1425H mm
Price	RM 3,699.00

HOOD

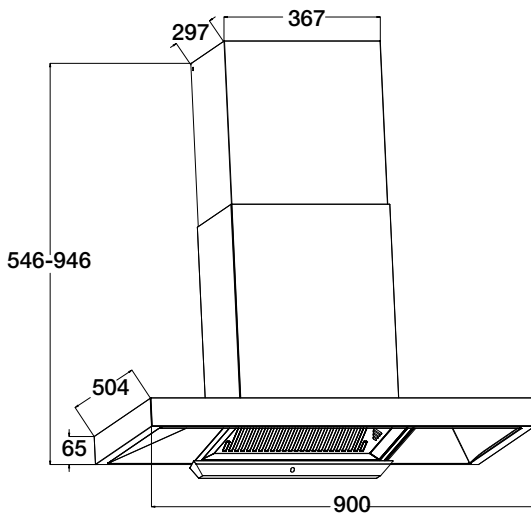

90CM 3 - S p e e d Wave Motion AC Motor T-Shape Hood

Art. No. 495.38.299	
Suction	1500m ³ /h
Panel Material	Black Glass
Body Material	Stainless Steel
Motor	AC motor
Panel Operation	T3 speed gesture and touch switch
Maintenance	Baffle filter
Oil Contena	Stainless Steel
Filter	2 Layer SS Filter
Product Dimension	900Wx 504D x 545-946H mm
Price RM	2,699.00

90CM 3 - S p e e d Wave Motion AC Motor Glass Hood

Art. No. 532.82.003	
Suction	1500m ³ /h
Panel Material	Black Glass
Body Material	Stainless Steel
Motor	AC motor
Panel Operation	Touch Panel with indication
Maintenance	Baffle filter
Oil Contena	Stainless Steel with Indication
Filter	2 Layer SS Filter
Product Dimension	889Wx 500D x 542-923H mm
Price RM	2,499.00

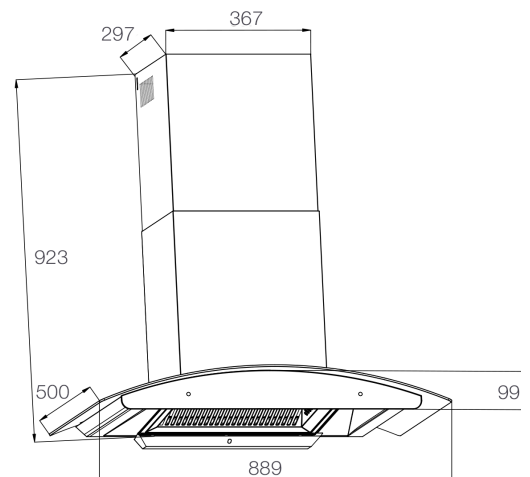

90CM 3-Speed Touch Panel T-Shape Hood



Art. No. 495.38.311	
Suction	1500m ³ /h
Panel Material	Black Glass
Body Material	Stainless Steel
Motor	AC motor with Seal
Panel Operation	3 speed Touch Panel
Oil Contena	Stainless steel with indication
	Charcoal Filter
Filter	2 Layer Filter
Product Dimension	900W x 504D x 623-1023H mm
Price RM 2,899.00	

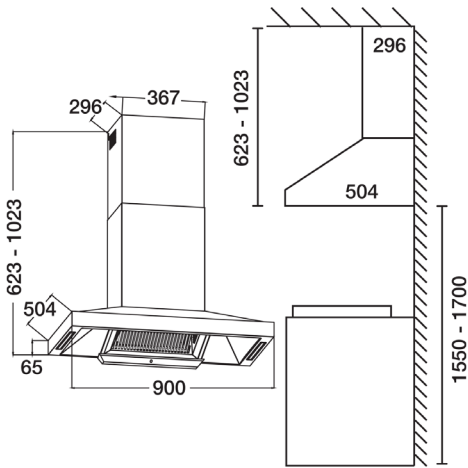

90CM 9-Speed Auto Heating DC Motor T-Shape Hood

Art. No. 495.38.312	
Suction	1700m ³ /h
Panel Material	Black Glass
Body Material	Stainless Steel
Motor	Silent DC- motor
Panel Operation	Touch Panel with Indication
Maintenance	Auto Clean Device
Oil Contena	Stainless oil container
	Charcoal Filter
Filter	2 Layer Filter
Product Dimension	895W x 480D x 575-975H mm
Price RM 3,499.00	

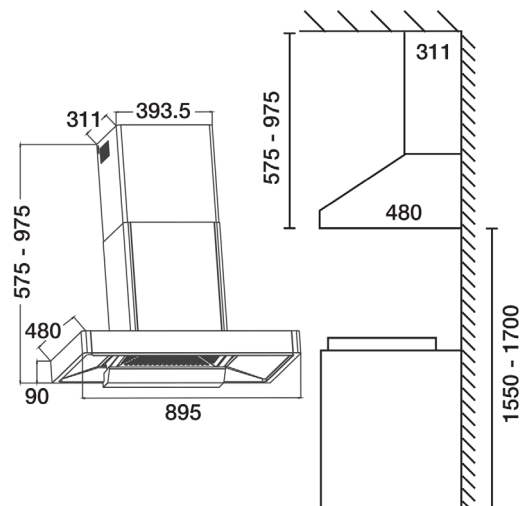

HOOD



90CM 2 - S p e e d Telescopic Hood

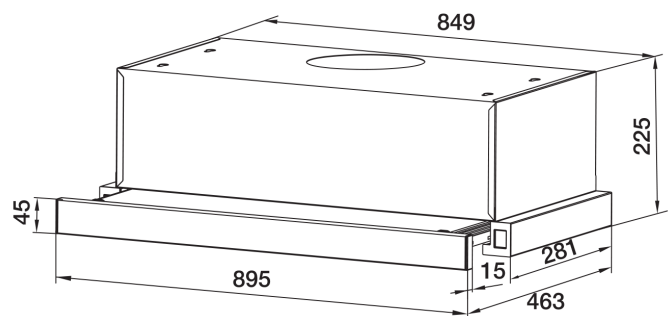
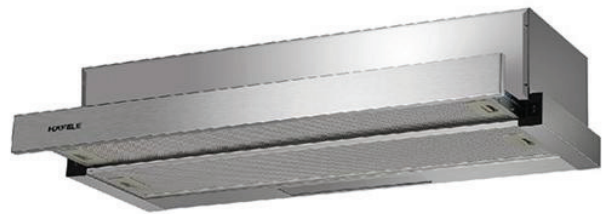

Art. No. 538.86.033	
Suction	700m ³ /h
Installation	Ventilation /Recycle
Speed	2
Noise Level	Below 50dB
Filter	2 Pieces of 5 Layers Aluminium
Product Dimension	895L x 296-300W x 225H mm
Warranty	1 Year
Price RM 1,399.00	



FRONT LOAD WASHER DRYER 10kg/6kg

Art. No. 533.93.110	
Washing Capacity	10kg
Drying Capacity	6kg
Max. Spin Speed	1400rpm
Sterilization Washing and Drying	
Steam Wash	
90°C Drum Wash	
Mid Way Reload	
Inverter BLDC Motor	
Product Dimension	595W x 665D x 845H mm
Price	RM6,399.00



FRONT LOAD WASHER DRYER 8kg/6kg

Art. No. 538.91.040	
Washing Capacity	8kg
Drying Capacity	6kg
Max. Spin Speed	1400rpm
Energy Efficiency	Class A
Motor	Brushless DC Electric Motor
180° Door Opening Angle	
Child lock Function	
16 Program	
Product Dimension	595W x 470D x 850H mm
Price	RM6,099.00

